

AGENDA

CANFIELD CITY COUNCIL
REGULAR MEETING

May 1, 2024-5:30 P.M.

FRANCIS J. McLAUGHLIN MUNICIPAL BUILDING

1. Call to Order.
2. Pledge of Allegiance.
3. Roll Call: Quorum is Present - Meeting is in Session.
4. Proclamations & Presentations.
5. Approval of Minutes.
6. Reading of Communications.
7. Reports of Committees, Boards, Mayor's Report, City Manager, Finance Director, Chief of Police, Zoning Inspector and Public Works Superintendent.
8. Public questions from residents (or representative) related to the above referenced reports. Questions may be limited to three (3) minutes.
9. Recognition of Persons Desiring to Appear Before Council.

10. OLD BUSINESS

Note: After each item is placed on the table for action, public comments from residents (or representative) as to that business item are received. May be limited to three (3) minutes per person and thirty (30) minutes total.

11. NEW BUSINESS

Note: After each item is placed on the table for action, public comments from residents (or representative) as to that business item are received. May be limited to three (3) minutes per person and thirty (30) minutes total.

- A. An Ordinance Authorizing Contract Modification Number 3 with MS Consultants, Inc to the 2024 Basic Engineering Services Agreement.

Description: This is Contract Modification #3 to the General Engineering Contract for MS Consultants, Inc. This Modification is for the Colonial Plaza Lift Station Generator Project in the amount of \$3,795.00

Action Needed: Passage of this Ordinance.

Attachment(s): Modification No. 3, Scope of Services

- B. An Ordinance Authorizing the City Manager to Purchase A Western Star Dump Truck, Dump Body and a Snowplow and Salt Spreader.

Description: The city is buying a Western Star Dump Truck and Dump Body from T.S.I. Truck and Equipment Sales and we are buying the Snowplow and Salt Spreader from Gledhill Road Machinery. The cost of the dump truck and dump body is \$113,037.00 and the cost of the snowplow and salt spreader is \$84,406.54. This was in the budget for 2024 and purchased through State Purchasing.

Action Needed: Passage of this Ordinance

Attachment(s): Specifications for the truck, snowplow and salt spreader.

- C. An **Ordinance** Declaring Surplus Property and Authorizing its Disposal and Declaring an Emergency.

Description: When it is determined that certain vehicles or equipment are no longer useful to, or needed by the City, Council must declare the items(s) as surplus and authorize the disposal of the items. This item is being sold to the Mahoning County Sheriff's Department.

Action Needed: Approval of Ordinance

Attachment(s): Specifications for the vehicle and the plow and spreader.

- D. A **Resolution** Authorizing the City Manager to Apply for, Accept, and Enter Into A Water Pollution Control Loan Fund (WPCLF) or Water Supply Revolving Loan Account (WSRLA) Agreement on Behalf of the City of Canfield for Planning and Construction of Wastewater or Water Facilities; and Designating A Dedicated Repayment Source for the Loan.

Description: The loan is for work on the Hilltop Water Tower.

Action Needed: Passage of this Resolution

Attachment(s):

- E. A **Motion** to Authorize the City Manager to Apply for F-1 and F-2 Permits as Applicable from the Ohio Department of Commerce/Division of Liquor Control for Family Fun Night on September 19, 2024 and Fall Fest on October 5, 2024.

Description: Ohio Revised Code Section 4303.20 dictates how F-type (beer, wine, liquor) permits are treated in the State of Ohio. F-Permits are temporary and are utilized for special functions and can be issued to the City of Canfield.

The Ohio Department of Commerce/Division of Liquor Control issues temporary Type "F" Permits to certain non-profits, including cities to allow for this type of activity. The City of Canfield has previously hosted events in which an F-1 Permit was obtained. This motion authorizes the City Manager to apply for F-1 (Beer only) or F-2 (Beer and Wine) permits for the upcoming September 19, 2024 Family Fun Night and the Fall Fest on October 5, 2024.

Action Needed: Approval of Motion

Attachment(s): Motion.

- F. A **Motion** Changing the Dates of City Council Meetings for the Months of July and August Pursuant to Section 3.09 of the Charter of the City of Canfield.

Description: Pursuant to Section 3.09 of the Charter of the City of Canfield, "regular meetings must be held twice each calendar month, except during the months of July and August, the Council may dispense with one of its regular meetings."

This Motion sets the date and time of the authorized one (1) meeting for the months of July and August. We are recommending July 17th and August 14th for the scheduled meetings.

Action Needed: Approve of Motion

Attachment(s): None.

G. A **Motion** Authorizing the Sale of a 2019 Chevrolet Tahoe to a Political Subdivision of the State.

Description: The Mahoning County Sheriff's Department is in need of a K-9 vehicle. Canfield wishes to sell the 2019 Tahoe to them for \$25,000. This does not have to go to Auction or be bid because they are a political subdivision of the state according to ORC 505.10.

Action Needed: Passage of this Motion

Attachment(s): Motion and Letter from Mahoning County Sheriff's Department.

12. Council Comments.

13. Adjournment

Introduced by: _____
First Reading: _____

ORDINANCE

**AN ORDINANCE AUTHORIZING CONTRACT MODIFICATION NUMBER 3 WITH
MS CONSULTANTS, INC TO THE 2024 BASIC ENGINEERING SERVICES AGREEMENT**

WHEREAS, the Council of the City of Canfield authorized the City Manager to enter into a contract with MS Consultants, Inc. on November 15, 2023 for General Engineering Services; and

WHEREAS, the City Manager and City Engineer recommends a Contract Modification Number 3, pursuant to section 1 and 4 of the contract; and

WHEREAS, this modification is for the development of bid solicitation documents, bidding services, and contract document preparation in accordance with Ohio EPA, WPCLF requirements; and

WHEREAS, Council desires to authorize Contract Modification Number 3 for the City of Canfield, Colonial Plaza Lift Station Generator Project.

NOW, THEREFORE, BE IT ORDAINED BY THE COUNCIL OF THE CITY OF CANFIELD, OHIO:

Section 1: Contract Modification Number 3 is hereby authorized in an amount of \$3,795.00 pursuant to the description and scope of work attached.

Section 2: That this Ordinance and all deliberations relating to the passage of this Ordinance were held in open meetings of this Council, all pursuant to Section 121.22 of the Ohio Revised Code and Section 3.11 of the Charter of the Municipality of Canfield.

PASSED IN COUNCIL THIS _____ DAY OF _____ A.D. 2024.

PRESIDENT OF COUNCIL

ATTEST:

CLERK OF COUNCIL

Certification of Publication

I, the undersigned Clerk of Council of the City of Canfield, Ohio, hereby certify that the foregoing Ordinance was posted in a prominent place at the Municipal Building, Canfield, Ohio for seven continuous days, to-wit: _____

_____.

CLERK OF COUNCIL

APPROVED AS TO FORM:

MUNICIPAL ATTORNEY

**MODIFICATION NO. 3
To
ENGINEERING AGREEMENT**

**FOR INCORPORATING THE PROFESSIONAL ENGINEERING SERVICES
FOR
*CITY OF CANFIELD: 2024 GENERAL ENGINEERING SERVICES***

1. **DATE:** April 17, 2024
2. **OWNER:** City of Canfield
3. **ORIGINAL AGREEMENT:** November 15, 2023
4. **CONSULTANT:** **ms consultants, inc.**
5. **MODIFICATIONS UNDER CONTRACT CLAUSES**

Section 1.4.7- Other professional engineering, architectural, and planning services as may be reasonably requested.

6. **REASON FOR MODIFICATION**

This modification is for the development of bid solicitation documents, bidding services, and contract document preparation in accordance with Ohio EPA WPCLF requirements. Please see attached Exhibit A for the scope of work.

7. **MODIFICATION IN AGREEMENT**

SECTION 3- PAYMENTS TO THE ENGINEER
SECTION 3.1 ADD:

For the Engineering Services described under Section 6 of this modification in agreement and in accordance with Paragraph 1.4.7 of the November 15, 2023 agreement, a lump sum fee of Three Thousand Seven Hundred Ninety-Five Dollars and No Cents (\$3,795.00).

All other parts of the Engineering Agreement are unchanged and remain in force.

IN WITNESS WHEREOF, the parties hereunto have caused this Modification No. 3 to be executed, as of the date and year first above written, by affixing the signature of the duly authorized officer of **ms consultants, inc.** and by the *City of Canfield*.

City of Canfield

By: _____

ms consultants, inc.

By: Steve Paxton

Title: Project Manager

Date: April 17, 2024

EXHIBIT A

SCOPE OF SERVICES

City of Canfield Colonial Plaza Lift Station Generator Project

April 17, 2024

Project Understanding

ms consultants, inc. (Engineer) understands that the City of Canfield (Owner) requests engineering services be provided to prepare bidding and contract documents for the above referenced project.

The Scope of Services for the project consists of the following:

1. Basic Services

- A. Engineer shall prepare bidding documents based upon Ohio EPA Water Pollution Control Loan Fund (WPCLF) requirements and the generator technical specifications as provided by the City.
- B. Engineer shall develop an Exhibit conceptual site plan for inclusion in the bid documents.
- C. Engineer shall coordinate with the Ohio EPA to ensure that all WPCLF requirements are met.
- D. Engineer shall prepare a bid solicitation and send to three contractors as selected by the City.
- E. Engineer shall attend the bid opening and coordinate the bid opening with Owner's staff.
- F. Engineer will prepare up to one addendum as part of the project.
- G. The Engineer will prepare a bid tabulation based upon the bid results and prepare an award recommendation letter for the Owner.
- H. The Engineer shall prepare final contract documents and provide to the Owner for coordination with the awarded contractor.

2. Owner's Responsibilities

- A. Designate in writing a person to act as Owner's representative with respect to the services to be rendered under this Agreement. Such person shall have complete authority to transmit instructions, receive information, interpret and define the Owner's policies and decisions with respect to Engineer's services for the project.
- B. Assist Engineer by placing at Engineer's disposal all available information pertinent to the project including previous reports and any other data relative to design or construction of the project.
- C. Arrange for access to and make all provisions for Engineer to enter upon public and private property as required for Engineer to perform services under this Agreement.

- D. Furnish approvals, pay for and secure all permits from all governmental authorities having jurisdiction over the project and such approvals and consents from others as may be necessary for completion of the project.
- E. Attend meetings and provide timely comments.
- F. Give prompt written notice to Engineer whenever the Owner observes or becomes aware of any development that affects the scope or timing of Engineer's services.
- G. Furnish, or direct Engineer to provide additional services as stipulated in this agreement or other services as required in a timely manner.
- H. Bear all costs incidental to compliance with the requirements of this Section 2.

3. Assumptions/Exclusions

- A. The project scope does not include design of the generator or appurtenances. Engineer shall use the technical information already obtained by the Owner.
- B. Engineer assumes that the contract is complete once final contract documents are provided to the Owner. Engineer assumes that the Owner will coordinate all field work with the contractor.
- C. The scope of work does not include Environmental Review.
- D. Attendance at a pre-construction meeting is not included.
- E. Construction services are not included.
- F. Permitting is not included.
- G. This agreement assumes one bid. Re-bids are not included as part of the project.
- H. The Engineers Estimate shall be based on quotes already obtained by the Owner.

4. Period of Service

- A. The Engineer agrees to complete the bidding documents within two weeks of an executed agreement for submittal to the Ohio EPA for review.

Introduced By: _____
First Reading: _____

ORDINANCE

AN ORDINANCE AUTHORIZING THE CITY MANAGER
TO PURCHASE A WESTERN STAR DUMP TRUCK,
DUMP BODY AND A SNOWPLOW AND SALT SPREADER.

WHEREAS, the Public Works Department has requested the purchase of a dump truck, 9' Dump Body, 11' and a snow plow and salt spreader; and

WHEREAS, Council desires to purchase the dump truck, dump body and a snowplow and salt spreader through the ODOT State Purchasing.

NOW, THEREFORE, BE IT ORDAINED BY THE COUNCIL OF THE CITY OF CANFIELD, OHIO:

Section 1: The City Manager is hereby authorized to purchase a Western Star dump truck, dump body and a snow plow and salt spreader through the ODOT State Purchasing (T.S.I Truck and Equipment Sales for the cab & chassis and Gledhill Road Machinery for snow plow and salt spreader).

Section 2: The total cost of the purchases shall not exceed \$197,443.54.

Section 3: That this Ordinance and all deliberations relating to the passage of this Ordinance were held in open meetings of this Council, all pursuant to Section 121.22 of the Ohio Revised Code and Section 3.11 of the Charter of the Municipality of Canfield.

PASSED IN COUNCIL THIS _____ DAY OF _____ A.D., 2024.

PRESIDENT OF COUNCIL

ATTEST:

CLERK OF COUNCIL

Certification of Publication

I, the undersigned Clerk of Council of the City of Canfield, hereby certify that the foregoing Ordinance was posted in a prominent place at the Municipal Building, Canfield, Ohio for seven continuous days, to-wit: _____

CLERK OF COUNCIL

APPROVED AS TO FORM:

MUNICIPAL ATTORNEY

Stock Muni Trucks

SPECIFICATION PROPOSAL

Data Code	Description	Weight Front	Weight Rear
Price Level			
PRL-27X	WST 47X/49X PRL-27X (EFF:MY24 ORDERS)		
Data Version			
DRL-010	SPECPRO21 DATA RELEASE VER 010		
Vehicle Configuration			
001-470	WESTERN STAR 47X	9,050	6,525
004-224	2024 MODEL YEAR SPECIFIED		
002-004	SET BACK AXLE - TRUCK		
019-006	TRAILER TOWING PROVISION AT END OF FRAME WITH SAE J560	10	10
003-001	LH PRIMARY STEERING LOCATION		
General Service			
AA1-003	TRUCK/TRAILER CONFIGURATION		
AA6-002	DOMICILED, USA (EXCLUDING CALIFORNIA AND CARB OPT-IN STATES)		
99D-010	NO 2008 CARB EMISSION CERTIFICATION		
AF2-998	NO STATE/PROVINCE INITIAL REGISTRATION SELECTED		
A85-011	CONSTRUCTION SERVICE		
A84-1GM	GOVERNMENT BUSINESS SEGMENT		
AA4-003	DRY BULK COMMODITY		
AA5-002	TERRAIN/DUTY: 100% (ALL) OF THE TIME, IN TRANSIT, IS SPENT ON PAVED ROADS		
AB1-008	MAXIMUM 8% EXPECTED GRADE		
AB5-001	SMOOTH CONCRETE OR ASPHALT PAVEMENT - MOST SEVERE IN-TRANSIT (BETWEEN SITES) ROAD SURFACE		
995-1A5	WESTERN STAR VOCATIONAL WARRANTY		

Data Code	Description	Weight Front	Weight Rear
A66-99D	EXPECTED FRONT AXLE(S) LOAD 16000.0 lbs		
A68-99D	EXPECTED REAR DRIVE AXLE(S) LOAD 22000.0 lbs		
A63-99D	EXPECTED GROSS VEHICLE WEIGHT CAPACITY 38000.0 lbs		
A70-99D	EXPECTED GROSS COMBINATION WEIGHT 80000.0 lbs		

Truck Service

AA3-018	FRONT PLOW/END DUMP BODY
AF3-1W0	HENDERSON

Tractor Service

AA2-005	FLATBED TRAILER
AH6-001	SINGLE (1) TRAILER

Engine

101-3BT	CUM L9 350 HP @ 2200 RPM; 2200 GOV RPM, 1050 LB-FT @ 1200 RPM	-850	-70
---------	---	------	-----

Electronic Parameters

79A-067	67 MPH ROAD SPEED LIMIT
79B-000	CRUISE CONTROL SPEED LIMIT SAME AS ROAD SPEED LIMIT
79K-007	PTO MODE ENGINE RPM LIMIT - 1100 RPM
79M-001	PTO MODE BRAKE OVERRIDE - SERVICE BRAKE APPLIED
79P-005	PTO RPM WITH CRUISE SET SWITCH - 1000 RPM
79U-007	PTO GOVERNOR RAMP RATE - 250 RPM PER SECOND
79V-001	FUEL DOSING OF AFTERTREATMENT ENABLED IN PTO MODE-CLEANS HYDROCARBONS AT HIGH TEMPERATURES ONLY
79W-024	CRUISE CONTROL BUTTON PTO CONTROL
79Y-002	PTO SPEED 2 SETTING - 1000 RPM
* 80P-998	NO FLEET SPEC FOR PARAMETERIZATION

Data Code	Description	Weight Front	Weight Rear
80G-002	PTO MINIMUM RPM - 700		
80J-002	REGEN INHIBIT SPEED THRESHOLD - 5 MPH		
80S-019	PTO 1, WITH SWITCH, TEM SUPPLIED REQUEST AND INTERLOCKS, WITH PTO CONNECTIONS, STATIONARY INTERLOCKS		
Engine Equipment			
99C-021	2010 EPA/CARB/GHG21 CONFIGURATION		
13E-001	STANDARD OIL PAN		
105-001	ENGINE MOUNTED OIL CHECK AND FILL		
014-111	SIDE OF HOOD AIR INTAKE WITH ENGINE MOUNTED AIR CLEANER, WITH INSIDE/OUTSIDE AIR AND SNOW DOOR		
124-1G3	DR 12V 215 AMP 38-SI BRUSHLESS QUADRAMOUNT PAD ALTERNATOR WITH REMOTE BATTERY VOLT SENSE		
292-222	(3) DTNA GENUINE, HIGH TEMP AGM STARTING AND CYCLING, MIN 2775CCA, 570RC, THREADED STUD BATTERIES		
290-1AC	PASSENGER SEAT BATTERY BOX VENTED TO OUTSIDE OF CAB		
282-013	BATTERY BOX MOUNTED UNDER PASSENGER SEAT		
291-017	WIRE GROUND RETURN FOR BATTERY CABLES WITH ADDITIONAL FRAME GROUND RETURN		
289-006	PLASTIC BATTERY BOX COVER		
293-058	POSITIVE LOAD DISCONNECT WITH CAB MOUNTED CONTROL SWITCH MOUNTED OUTBOARD DRIVER SEAT	2	
295-029	POSITIVE AND NEGATIVE POSTS FOR JUMPSTART LOCATED ON FRAME NEXT TO STARTER	2	
107-032	CUMMINS TURBOCHARGED 18.7 CFM AIR COMPRESSOR WITH INTERNAL SAFETY VALVE		
152-041	ELECTRONIC ENGINE INTEGRAL SHUTDOWN PROTECTION SYSTEM		
128-032	C-BRAKE BY JACOBS WITH LOW/OFF/HIGH BRAKING DASH SWITCH		
016-1C2	RH OUTBOARD UNDER STEP MOUNTED HORIZONTAL AFTERTREATMENT SYSTEM ASSEMBLY WITH RH B-PILLAR MOUNTED VERTICAL TAILPIPE		
28F-015	ENGINE AFTERTREATMENT DEVICE, AUTOMATIC OVER		

Data Code	Description	Weight Front	Weight Rear
	THE ROAD ACTIVE REGENERATION AND VIRTUAL REGENERATION REQUEST SWITCH IN CLUSTER AND DASH MOUNTED INHIBIT SWITCH		
239-003	90 DEG STACK AND B-PILLAR PIPE WITH MINIMUM STACK PROTRUSION ABOVE CAB		
237-1CR	RH CURVED VERTICAL TAILPIPE B-PILLAR MOUNTED ROUTED FROM STEP		
23U-027	8 GALLON DIESEL EXHAUST FLUID TANK		
23Z-005	UNPOLISHED ALUMINUM WST DIESEL EXHAUST FLUID TANK COVER		
43X-001	LH HEAVY DUTY STANDARD DIESEL EXHAUST FLUID TANK LOCATION		
43Y-001	STANDARD DIESEL EXHAUST FLUID TANK CAP		
242-001	STAINLESS STEEL AFTERTREATMENT DEVICE/MUFFLER/TAILPIPE SHIELD		
273-058	AIR POWERED ON/OFF ENGINE FAN CLUTCH		
276-001	AUTOMATIC FAN CONTROL WITHOUT DASH SWITCH, NON ENGINE MOUNTED		
122-1H3	DETROIT FUEL/WATER SEPARATOR WITH WATER IN FUEL SENSOR	10	
110-003	CUMMINS SPIN ON FUEL FILTER		
118-008	COMBINATION FULL FLOW/BYPASS OIL FILTER		
266-107	1400 SQUARE INCH VOCATIONAL RADIATOR		
103-039	ANTIFREEZE TO -34F, OAT (NITRITE AND SILICATE FREE) EXTENDED LIFE COOLANT		
171-007	GATES BLUE STRIPE COOLANT HOSES OR EQUIVALENT		
261-001	STANDARD CHARGE AIR COOLER PLUMBING		
270-016	RADIATOR DRAIN VALVE		
168-002	LOWER RADIATOR GUARD		
138-011	PHILLIPS-TEMRO 1000 WATT/115 VOLT BLOCK HEATER	4	
140-022	CHROME ENGINE HEATER RECEPTACLE MOUNTED UNDER LH DOOR		

Data Code	Description	Weight Front	Weight Rear
132-004	ELECTRIC GRID AIR INTAKE WARMER		
155-055	DELCO 12V 39MT HD/OCP STARTER WITH THERMAL PROTECTION AND INTEGRATED MAGNETIC SWITCH	-45	
Transmission			
342-582	ALLISON 3000 RDS AUTOMATIC TRANSMISSION WITH PTO PROVISION	-230	-130
Transmission Equipment			
343-339	ALLISON VOCATIONAL PACKAGE 223 - AVAILABLE ON 3000/4000 PRODUCT FAMILIES WITH VOCATIONAL MODELS RDS, HS, MH AND TRV		
84B-012	ALLISON VOCATIONAL RATING FOR ON/OFF HIGHWAY APPLICATIONS AVAILABLE WITH ALL PRODUCT FAMILIES		
84C-023	PRIMARY MODE GEARS, LOWEST GEAR 1, START GEAR 1, HIGHEST GEAR 6, AVAILABLE FOR 3000/4000 PRODUCT FAMILIES ONLY		
84D-023	SECONDARY MODE GEARS, LOWEST GEAR 1, START GEAR 1, HIGHEST GEAR 6, AVAILABLE FOR 3000/4000 PRODUCT FAMILIES ONLY		
84E-000	PRIMARY SHIFT SCHEDULE RECOMMENDED BY DTNA AND ALLISON, THIS DEFINED BY ENGINE AND VOCATIONAL USAGE		
84F-000	SECONDARY SHIFT SCHEDULE RECOMMENDED BY DTNA AND ALLISON, THIS DEFINED BY ENGINE AND VOCATIONAL USAGE		
84G-000	PRIMARY SHIFT SPEED RECOMMENDED BY DTNA AND ALLISON, THIS DEFINED BY ENGINE AND VOCATIONAL USAGE		
84H-000	SECONDARY SHIFT SPEED RECOMMENDED BY DTNA AND ALLISON, THIS DEFINED BY ENGINE AND VOCATIONAL USAGE		
84N-200	FUEL SENSE 2.0 DISABLED - PERFORMANCE - TABLE BASED		
84V-001	DIRECTION CHANGE ENABLED WITH MULTIPLEXED SERVICE BRAKES - ALLISON 5TH GEN TRANSMISSIONS		
85E-007	MAXIMUM ENGINE SPEED FOR PTO ENGAGEMENT 800 RPM		
85H-159	MAXIMUM OUTPUT SPEED FOR PTO OPERATION 4000 RPM - ALLISON 5TH GEN TRANSMISSIONS		
353-074	QUICKFIT BODY LIGHTING CONNECTOR UNDER CAB, WITH BLUNT CUTS		
34C-011	ELECTRONIC TRANSMISSION WIRING TO CUSTOMER INTERFACE CONNECTOR		

Data Code	Description	Weight Front	Weight Rear
362-823	CUSTOMER INSTALLED CHELSEA 280 SERIES PTO		
363-001	PTO MOUNTING, LH SIDE OF MAIN TRANSMISSION ALLISON		
341-018	MAGNETIC PLUGS, ENGINE DRAIN, TRANSMISSION DRAIN, AXLE(S) FILL AND DRAIN		
345-078	HEAVY DUTY ELECTRONIC TRANSMISSION SHIFT CONTROL, COLUMN MOUNTED		
370-006	WATER TO OIL TRANSMISSION COOLER		
346-003	TRANSMISSION OIL CHECK AND FILL WITH ELECTRONIC OIL LEVEL CHECK		
35T-001	SYNTHETIC TRANSMISSION FLUID (TES-295 COMPLIANT)		

Front Axle and Equipment

400-1BA	DETROIT DA-F-18.0-5 18,000# FL1 71.0 KPI/3.74 DROP SINGLE FRONT AXLE	90	
418-060	CONMET PRESET PLUS PREMIUM IRON FRONT HUBS	20	
402-075	BENDIX ADB22X AIR DISC FRONT BRAKES	20	
403-002	NON-ASBESTOS FRONT BRAKE LINING		
419-004	FRONT DISC BRAKE ROTORS		
427-001	FRONT BRAKE DUST SHIELDS		
409-006	FRONT OIL SEALS		
408-001	VENTED FRONT HUB CAPS WITH WINDOW, CENTER AND SIDE PLUGS - OIL		
405-030	FRONT AIR DISC BRAKE INTERNAL ADJUSTERS		
536-104	DUAL POWER STEERING GEARS, BENDIX 16-20K	80	
534-003	4 QUART POWER STEERING RESERVOIR	5	
533-001	OIL/AIR POWER STEERING COOLER	5	
40T-002	CURRENT AVAILABLE SYNTHETIC 75W-90 FRONT AXLE LUBE		

Front Suspension

Data Code	Description	Weight Front	Weight Rear
620-013	18,000# TAPERLEAF FRONT SUSPENSION	145	
619-005	MAINTENANCE FREE RUBBER BUSHINGS - FRONT SUSPENSION		
410-001	FRONT SHOCK ABSORBERS		
Rear Axle and Equipment			
420-051	RS-23-160 23,000# R-SERIES SINGLE REAR AXLE		-2,260
450-060	CONMET PRESET PLUS PREMIUM IRON REAR HUBS		30
421-614	6.14 REAR AXLE RATIO		
424-001	IRON REAR AXLE CARRIER WITH STANDARD AXLE HOUSING		
386-074	MXL 176T MERITOR EXTENDED LUBE MAIN DRIVELINE WITH HALF ROUND YOKES	-75	-75
388-998	NO INTERAXLE (#3) DRIVELINE		
452-001	DRIVER CONTROLLED TRACTION DIFFERENTIAL - SINGLE REAR AXLE		20
878-018	(1) DRIVER CONTROLLED DIFFERENTIAL LOCK REAR VALVE FOR SINGLE DRIVE AXLE		
87B-008	INDICATOR LIGHT FOR EACH DIFFERENTIAL LOCKOUT SWITCH		
423-075	BENDIX ADB22X AIR DISC REAR BRAKES		-30
433-002	NON-ASBESTOS REAR BRAKE LINING		
434-012	BRAKE CAMS AND CHAMBERS ON REAR SIDE OF DRIVE AXLE(S)		
451-005	REAR DISC BRAKE ROTORS		
425-002	REAR BRAKE DUST SHIELDS		5
440-006	REAR OIL SEALS		
426-1AH	AIR DISC LONGSTROKE 1-DRIVE AXLE SPRING PARKING CHAMBERS		-20
428-030	REAR AIR DISC BRAKE INTERNAL ADJUSTERS		
41T-002	CURRENT AVAILABLE SYNTHETIC 75W-90 REAR AXLE LUBE		

Data Code	Description	Weight Front	Weight Rear
42T-001	STANDARD REAR AXLE BREATHER(S)		
Rear Suspension			
622-1DC	26,000# FLAT LEAF SPRING REAR SUSPENSION WITH HELPER AND RADIUS ROD		140
621-108	9.5 INCH NOMINAL RIDE HEIGHT (460MM GLOBAL REFERENCE HEIGHT)		
431-001	STANDARD AXLE SEATS IN AXLE CLAMP GROUP		
623-005	FORE/AFT CONTROL RODS		
439-998	NO REAR SHOCK ABSORBERS		-30
Brake System			
490-1AU	WABCO 4S/4M ABS WITH TRACTION CONTROL WITH ATC SHUT OFF SWITCH		
871-001	REINFORCED NYLON, FABRIC BRAID AND WIRE BRAID CHASSIS AIR LINES		
432-003	RELAY VALVE WITH 5-8 PSI CRACK PRESSURE, NO REAR PROPORTIONING VALVE		
480-040	WABCO SYSTEM SAVER 1200 HEATED AIR DRYER WITH PRESSURE CONTROL VALVE		
483-004	WABCO OIL COALESCING FILTER FOR AIR DRYER		
479-012	AIR DRYER MOUNTED UNDER HOOD		
460-015	ALUM AIR TANKS MOUNTED BELOW FRAME RAILS	-25	-25
477-004	PULL CABLES ON ALL AIR RESERVOIR(S)		
Trailer Connections			
914-025	AIR CONNECTIONS TO END OF FRAME WITH GLAD HANDS FOR TRUCK AND DUST COVERS		
296-010	PRIMARY CONNECTOR/RECEPTACLE WIRED FOR SEPARATE STOP/TURN, ABS CENTER PIN POWERED THROUGH IGNITION		
303-025	SAE J560 7-WAY PRIMARY TRAILER CABLE RECEPTACLE MOUNTED END OF FRAME		
Wheelbase & Frame			
545-407	4075MM (160 INCH) WHEELBASE		
546-107	15.0MM X 89.0MM X 315.0MM STEEL FRAME (0.59X3.	-10	580

Data Code	Description	Weight Front	Weight Rear
	5X12.4 INCH) 120 KSI		
552-004	1550MM (61 INCH) REAR FRAME OVERHANG		
55W-006	FRAME OVERHANG RANGE: 61 INCH TO 70 INCH	-40	110
549-002	24 INCH INTEGRAL FRONT FRAME EXTENSION	140	
AC8-99D	CALC'D BACK OF CAB TO REAR SUSP C/L (CA) 95.28 in		
AE4-99D	CALC'D FRAME LENGTH - OVERALL 290.37 in		
ZF1-99D	FRAME HEIGHT TOP FRONT UNLADEN 44.71 in		
ZF2-99D	FRAME HEIGHT TOP FRONT LADEN 41.26 in		
ZF3-99D	FRAME HEIGHT TOP REAR UNLADEN 43.83 in		
ZF4-99D	FRAME HEIGHT TOP REAR LADEN 40.86 in		
553-001	SQUARE END OF FRAME		
559-001	STANDARD WEIGHT ENGINE CROSSMEMBER		
561-015	STANDARD CAST ALUMINUM CROSSMEMBER BACK OF TRANSMISSION		
562-063	STANDARD CAST ALUMINUM MIDSHIP		
572-078	HEAVY DUTY REAR C-CHANNEL CROSSMEMBER, NON-TOWING		70
565-001	STANDARD SUSPENSION CROSSMEMBER		20
N 568-012	CAST ALUMINUM REAR SUSPENSION CROSSMEMBER		

Chassis Equipment

025-001	UNPOLISHED ALUMINUM WST EQUIPMENT COVERS		
556-127	BRIGHT STEEL 1/8 INCH VOCATIONAL BUMPER		
558-998	NO FRONT TOW HOOKS	-15	
574-998	NO LICENSE PLATE MOUNTING		
551-002	HUCK-SPIN ROUND COLLAR CHASSIS FASTENERS		

Data Code	Description	Weight Front	Weight Rear
44Z-002	EXTERIOR HARNESSSES WRAPPED IN ABRASION TAPE		
Fuel Tanks			
204-154	80 GALLON/302 LITER ALUMINUM FUEL TANK - LH	10	
218-006	25 INCH DIAMETER FUEL TANK(S)		
215-007	PLAIN ALUMINUM/PAINTED STEEL FUEL/HYDRAULIC TANK(S) WITH POLISHED STAINLESS STEEL BANDS		
212-007	FUEL TANK(S) FORWARD		
664-002	POLISHED STEP FINISH		
205-001	FUEL TANK CAP(S)		
216-020	EQUIFLO INBOARD FUEL SYSTEM		
202-016	HIGH TEMPERATURE REINFORCED NYLON FUEL LINE		
Tires			
093-1YU	CONTINENTAL HAU 3 WT 315/80R22.5 20 PLY RADIAL FRONT TIRES	100	
094-2A7	MICHELIN XDS2 11R22.5 16 PLY RADIAL REAR TIRES		96
Wheels			
502-664	ALCOA ULTRA ONE 89U63X 22.5X9.00 10-HUB PILOT 3.12 INSET 10-HD ALUMINUM FRONT WHEELS	-44	
505-766	ALCOA ULA18X 22.5X8.25 10-HUB PILOT ALUMINUM DISC REAR WHEELS		
50T-998	NO FRONT AXLE WHEEL/HUB COVER		
50X-998	NO WHEEL/HUB COVER-PUSHER/TAG		
496-011	FRONT WHEEL MOUNTING NUTS		
497-011	REAR WHEEL MOUNTING NUTS		
Cab Exterior			
829-053	111.6 INCH BBC CONVENTIONAL ALUMINUM CAB		
82A-028	STAINLESS STEEL CAB ACCENT MOLDING		

Data Code	Description	Weight Front	Weight Rear
667-001	FRONT FENDERS		
754-017	BOLT-ON MOLDED FLEXIBLE FENDER EXTENSIONS	10	
678-066	INTERIOR GRAB HANDLES WITH ADDED LOWER LH AND RH A PILLAR GRAB HANDLES AND LH AND RH EXTERIOR NON-SLIP GRAB HANDLES		
65X-010	BRIGHT HOOD MOUNTED AIR INTAKE GRILLE, BLACK SCREEN, WITH LED ACCENT LIGHTS		
640-016	X-SERIES STEEL REINFORCED ALUMINUM CAB		
644-048	X-SERIES VOCATIONAL HOOD		
67U-001	HOOD OPENING ASSIST WITH LOCKING STRUT		
652-016	WESTERN STAR NAMEPLATES		
727-012	DUAL HADLEY SD-978 26 INCH RECTANGULAR AIR HORNS		
726-002	DUAL ELECTRIC HORNS		
575-001	REAR LICENSE PLATE MOUNT END OF FRAME		
312-095	DUAL STAGE INTELLIGENT LED HEADLIGHTS WITH HEATED LENS SYSTEM		
302-073	VISOR MOUNTED LED MARKER LIGHTS		
314-824	WIRING AND SWITCH FOR CUSTOMER FURNISHED SNOW PLOW LAMPS WITH DUAL CONNECTIONS AT BUMPER		
311-001	DAYTIME RUNNING LIGHTS		
294-1AY	INTEGRAL LED STOP/TAIL/BACKUP LIGHTS		
300-043	LED SIDE TURN SIGNAL		
31K-800	SWITCH & WIRING TO LH/RH OF DASH FOR C/F MIRROR MOUNTED UTILITY LIGHTS		
744-105	C-BAR MIRROR SYSTEM WITH DUAL HEATED MIRRORS WITH INTEGRAL HEATED CONVEX, DUAL REMOTE, STAINLESS STEEL BACK COVER, AND BRIGHT C-BAR	20	
796-001	102 INCH EQUIPMENT WIDTH		
743-209	LH AND RH CONVEX MIRRORS INTEGRAL WITH PRIMARY MIRRORS		

Data Code	Description	Weight Front	Weight Rear
74A-001	RH DOWN VIEW MIRROR		
729-001	STANDARD SIDE/REAR REFLECTORS		
677-098	UNPOLISHED ALUMINUM WST AFTERTREATMENT SYSTEM COVER		
764-020	STAINLESS STEEL EXTERIOR SUN VISOR WITH INTEGRAL MARKER LIGHTS	16	
768-065	HIGH VISIBILITY 3-PIECE SOLAR TINTED REAR WINDOW, (1) 31 INCH X 20 INCH SOLAR TINTED REAR WINDOW, (2) 9 INCH X 20 INCH	20	
663-019	1-PIECE ROPED-IN SOLAR GREEN GLASS WINDSHIELD		
659-006	8 LITER (2 GAL) WINDSHIELD WASHER RESERVOIR, CAB MOUNTED, WITH FLUID LEVEL INDICATOR		
Cab Interior			
055-015	X-SERIES BASE INTERIOR TRIM LEVEL PACKAGE		
707-1C3	CHARCOAL BLACK VINYL BASE LEVEL INTERIOR		
70K-016	CARBON WITH BASE BLACK ACCENT		
772-001	BLACK MATS		
785-014	(2) DASH MOUNTED POWER OUTLETS AND COIN TRAY		
691-001	FORWARD ROOF MOUNTED CONSOLE		
693-019	LH AND RH DOOR STORAGE POCKETS INTEGRATED INTO MOLDED DOOR PANELS		
741-015	(2) COAT HOOKS ON BACKWALL OF CAB		
738-021	DIGITAL ALARM CLOCK IN DRIVER DISPLAY		
720-072	2-1/2 LB. FIRE EXTINGUISHER SHIPPED LOOSE IN CAB	5	
170-015	STANDARD HEATER PLUMBING		
698-001	RADIATOR MOUNTED AIR CONDITIONER CONDENSER		
739-034	PREMIUM INSULATION		
324-1B3	STANDARD LED CAB LIGHTING		

Data Code	Description	Weight Front	Weight Rear
787-998	NO SECURITY DEVICE		
657-001	DOOR LOCKS AND IGNITION SWITCH KEYED THE SAME		
78G-003	KEY QUANTITY OF 3		
655-028	LH AND RH ELECTRIC DOOR LOCKS WITH AUTO UNLOCK FEATURE WHEN DOOR IS SET FROM OPEN TO CLOSED POSITION		
64C-002	BRIGHT DOOR HANDLES		
722-029	TRIANGULAR REFLECTORS KIT WITH FLARES SHIPPED LOOSE IN CAB	12	
756-1J7	ELITE 2.0 HIGH BACK AIR SUSPENSION DRIVER SEAT W/2 AIR LUMBAR,ACTIVE BOLSTER,INTEGRATED CUSHION EXTENSION, TILT,ADJUSTABLE SHOCK, MAP POCKET, HEAT & VENTILATION	30	
760-294	BATTERY BOX MID BACK NON SUSPENSION PASSENGER SEAT		
757-001	BLACK SUSPENSION COVER FOR AIR DRIVER SEAT	2	
759-007	DUAL DRIVER SEAT ARMRESTS, NO PASSENGER SEAT ARMRESTS		
758-135	BLACK MORDURA CLOTH DRIVER SEAT COVER WITH EMBROIDERED LOGO		
761-138	BLACK MORDURA CLOTH PASSENGER SEAT COVER WITH NO LOGO		
763-1AA	3 POINT ADJUSTABLE D-RING RETRACTOR DRIVER AND FIXED D-RING RETRACTOR PASSENGER SEAT BELTS		
532-002	ADJUSTABLE TILT AND TELESCOPING STEERING COLUMN		
540-044	4-SPOKE 18 INCH (450MM) BLACK STEERING WHEEL WITH SWITCHES		
765-002	DRIVER AND PASSENGER INTERIOR SUN VISORS		

Instruments & Controls

185-004	STANDARD FOOT PEDAL SYSTEM		
106-002	ELECTRONIC ACCELERATOR CONTROL		
87L-003	ENGINE REMOTE INTERFACE WITH PARK BRAKE AND NEUTRAL INTERLOCKS		
870-001	BLACK GAUGE BEZELS		

Data Code	Description	Weight Front	Weight Rear
734-018	STANDARD CENTER INSTRUMENT PANEL		
840-001	DUAL NEEDLE PRIMARY AND SECONDARY AIR PRESSURE GAUGE		
198-002	INTAKE MOUNTED AIR RESTRICTION INDICATOR WITH GRADUATIONS		
721-021	87 DB TO 112 DB SELF-ADJUSTING BACKUP ALARM		3
149-015	ELECTRONIC CRUISE CONTROL WITH CONTROLS ON STEERING WHEEL SPOKES		
156-007	KEY OPERATED IGNITION SWITCH AND INTEGRAL START POSITION; 4 POSITION OFF/RUN/START/ACCESSORY		
811-044	PREMIUM INSTRUMENT CLUSTER WITH 5.0 INCH TFT COLOR DISPLAY		
81B-003	DIGITAL PANEL LAMP DIMMER SWITCH IN DRIVER DISPLAY		
160-045	HEAVY DUTY ONBOARD DIAGNOSTICS INTERFACE CONNECTOR WITH DUST CAP LOCATED BELOW LH DASH		
844-001	2 INCH ELECTRIC FUEL GAUGE		
148-072	ENGINE REMOTE INTERFACE WITH ONE OR MORE SET SPEEDS		
856-001	ELECTRICAL ENGINE COOLANT TEMPERATURE GAUGE		
854-998	NO ENGINE OIL TEMPERATURE GAUGE		
852-002	ELECTRIC ENGINE OIL PRESSURE GAUGE		
864-001	2 INCH TRANSMISSION OIL TEMPERATURE GAUGE		
867-004	ELECTRONIC OUTSIDE TEMPERATURE SENSOR DISPLAY IN DRIVER MESSAGE CENTER		
830-017	ENGINE AND TRIP HOUR METERS INTEGRAL WITHIN DRIVER DISPLAY		
372-123	PTO CONTROLS FOR ENHANCED VEHICLE ELECTRIC/ELECTRONIC ARCHITECTURE		
736-998	NO OBSTACLE DETECTION SYSTEM		
49B-998	NO VEHICLE STABILITY ADVISOR OR CONTROL		
73B-998	NO LANE DEPARTURE WARNING SYSTEM		

Data Code	Description	Weight Front	Weight Rear
35M-013	2 QUICKFIT PROGRAMMABLE INTERFACE MODULES	20	
6TS-005	TMC RP1226 ACCESSORY CONNECTOR LOCATED BEHIND PASSENGER SIDE REMOVEABLE DASH PANEL		
746-137	AM/FM/WB WORLD TUNER RADIO WITH BLUETOOTH, USB AND AUXILIARY INPUTS, J1939		
747-001	DASH MOUNTED RADIO		
750-041	STANDARD SPEAKER SYSTEM		
753-998	NO AM/FM RADIO ANTENNA		
748-045	UNIDEN BEARCAT 880 FACTORY INSTALLED CB RADIO WITH 10 CHANNEL WEATHERBAND	5	
749-001	ROOF/OVERHEAD CONSOLE CB RADIO PROVISION		
751-001	SINGLE REMOTE SPEAKER WITH LEAD FOR 2-WAY RADIO		
752-004	SINGLE FIBERGLASS LH MIRROR MOUNTED CB ANTENNA WITH BRACKET AND LEAD		
75W-001	HEADLINER MULTI-BAND ANTENNA: AM/FM/WEATHERBAND, WIFI/BLUETOOTH, GNSS/GPS		
810-027	ELECTRONIC MPH SPEEDOMETER WITH SECONDARY KPH SCALE, WITHOUT ODOMETER		
812-032	ELECTRONIC 2500 RPM TACHOMETER		
813-1C8	DETROIT CONNECT PLATFORM HARDWARE		
8D1-305	5 YEARS DAIMLER CONNECTIVITY BASE PACKAGE (FEATURES VARY BY MODEL) POWERED BY DETROIT CONNECT		
162-002	IGNITION SWITCH CONTROLLED ENGINE STOP		
81Y-005	PRE-TRIP INSPECTION FEATURE FOR EXTERIOR LAMPS ONLY		
482-001	BW TRACTOR PROTECTION VALVE		
842-998	NO TURBO AIR PRESSURE GAUGE		
836-015	DIGITAL VOLTAGE DISPLAY INTEGRAL WITH DRIVER DISPLAY		
304-030	ROTARY HEADLAMP SWITCH, MARKER LIGHTS/HEADLIGHTS SWITCH WITH PULL OUT FOR OPTIONAL FOG/ROAD LAMPS		

Data Code	Description	Weight Front	Weight Rear
882-021	TWO VALVE PARKING BRAKE SYSTEM WITH DASH VALVE CONTROL AUTONEUTRAL AND WARNING INDICATOR		
299-020	SELF CANCELING TURN SIGNAL SWITCH WITH DIMMER, HEADLAMP FLASH, WASH/WIPE/INTERMITTENT		
48H-001	QUICKFIT POWERTRAIN INTERFACE CONNECTOR LOCATED BETWEEN SEATS WITH CAPS		
* 4CH-006	6 EXTRA PROGRAMMABLE SWITCHES/INDICATORS		
	\$A1A0082ZZ,A1B0083ZZ,A1C0084ZZ,A1D0085ZZ ,A1E0176ZZ,A1F0177ZZ		
48C-006	QUICKFIT PROGRAMMABLE INTERFACE CONNECTORS 1 & 2 BETWEEN SEATS WITH BLUNTCUTS		

Design

065-000 PAINT: ONE SOLID COLOR

Color

980-5F6 CAB COLOR A: L0006EY WHITE ELITE EY

986-020 BLACK, HIGH SOLIDS POLYURETHANE CHASSIS PAINT

Certification / Compliance

996-001 U.S. FMVSS CERTIFICATION, EXCEPT SALES CABS AND GLIDER KITS

Secondary Factory Options

- * 84J-000 ENG BRK PRESLECT - DTNA STANDARD ENGINE BRAKE RANGE
- * 84K-000 ALT ENG BRK PRESLECT - DTNA STD ALT ENGINE BRAKE PRESLECT
- * 97G-004 TRANS PROG-ENABLED 2013
- * 84U-000 DRIVER SW INPUT - DEFAULT - NO SWITCHES

Sales Programs

NO SALES PROGRAMS HAVE BEEN SELECTED

TOTAL VEHICLE SUMMARY

Weight Summary

	Weight Front	Weight Rear	Total Weight
Factory Weight+	8499 lbs	4969 lbs	13468 lbs
Total Weight+	8499 lbs	4969 lbs	13468 lbs

PMV-021	GHG21 ENHANCEMENT PRICE
PNV-998	NO CARB24 PRICING IMPACT
RD1-305	5 YRS DAIMLER CONNECTIVITY BASE PKG (VARY BY MODEL) POWERED BY DETROIT CONNECT
RFY-022	FRONT TIRE SURCHARGE
RFU-022	REAR TIRE SURCHARGE
RFZ-024	MY24/CY23 PRICING SURCHARGE
P73-2WS	STANDARD DESTINATION CHARGE

Extended Warranty

WAI-47H	CUM 2017 L9: HD1 MD DTY 5 YEARS / 100,000 MILES / 161,000 KM EXTENDED WARRANTY. FEX APPLIES
WAX-101	CUM 2017 L9: AT3 MD DTY 5 YEARS / 100,000 MILES / 161,000 KM AFTERTREATMENT. FEX APPLIES

(+) Weights Shown are estimates only.
 If weight is critical, contact Customer Application Engineering.

(**) Prices shown do not include taxes, fees, etc... "Net Equipment Selling Price" is located on the Quotation Details Proposal Report.

(***) All cost increases for major components (Engines, Transmissions, Axles, Front and Rear Tires) and government mandated requirements, tariffs, and raw material surcharges will be passed through and added to factory invoices.

DIMENSIONS

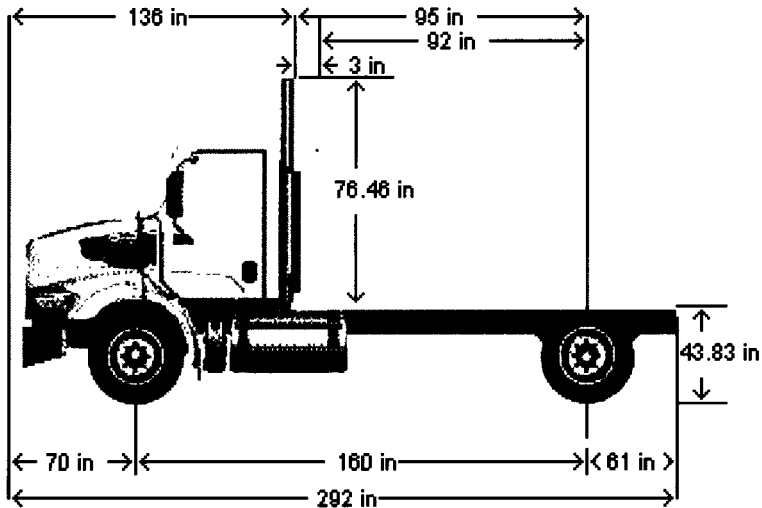

VEHICLE SPECIFICATIONS SUMMARY - DIMENSIONS

Model	47X
Wheelbase (545)	4075MM (160 INCH) WHEELBASE
Rear Frame Overhang (552)	1550MM (61 INCH) REAR FRAME OVERHANG
Fifth Wheel (578)	NO FIFTH WHEEL
Mounting Location (577)	NO FIFTH WHEEL LOCATION
Maximum Forward Position (in)	0
Maximum Rearward Position (in)	0
Amount of Slide Travel (in)	0
Slide Increment (in)	0
Desired Slide Position (in)	0.0
Cab Size (829)	111.6 INCH BBC CONVENTIONAL ALUMINUM CAB
Sleeper (682)	NO SLEEPER BOX/SLEEPERCAB
Exhaust System (016)	RH OUTBOARD UNDER STEP MOUNTED HORIZONTAL AFTERTREATMENT SYSTEM ASSEMBLY WITH RH B-PILLAR MOUNTED VERTICAL TAILPIPE

TABLE SUMMARY - DIMENSIONS

Dimensions	Inches
Skupper to Back of Cab (SB/C)	135.6
Skupper to Centerline of Front Axle (SA)	70.5
Front Axle to Back of Cab (AC)	65.2
Min. Cab to Body Clearance (CB)	3.0
Back of Cab to Centerline of Rear Axle(s) (CA)	95.3
Effective Back of Cab to Centerline of Rear Axle(s) (Effective CA)	92.3
Back of Cab Protrusions (Exhaust/Intake) (CP)	2.0
Back of Cab Protrusions (Ride Extenders/Tire Tab) (CP)	0.0
Back of Cab Protrusions (CNC Tank)	0.0
Back of Cab Clearance (CL)	3.0
Back of Cab to End of Frame	156.3
Cab Height (CH)	76.5
Wheelbase (WB)	160.4
Frame Overhang (OH)	61.0
Overall Frame Length	290.4
Overall Length (OAL)	291.9
Rear Axle Spacing	0.0
Unladen Frame Height at Centerline of Rear Axle	43.8

Performance calculations are estimates only. If performance calculations are critical, please contact Customer Application Engineering.

Introduced by: _____
First Reading: _____

ORDINANCE

AN ORDINANCE DECLARING SURPLUS PROPERTY
AND AUTHORIZING ITS DISPOSAL AND DECLARING AN EMERGENCY

WHEREAS, the City Manager has recommended that certain vehicles are no longer needed by the City; and

WHEREAS, Council desires to declare the following vehicle surplus and dispose of it.

NOW, THEREFORE, BE IT ORDAINED BY THE COUNCIL OF THE CITY OF CANFIELD, OHIO:

Section 1: The following vehicle and accessories are hereby declared surplus:

2019 Chevrolet Tahoe Vin#1GNSKAKC3KR150660

Section 2: The City Manager is hereby authorized to dispose of the listed vehicle in accordance with the applicable City of Canfield Ordinances.

Section 3: That this Ordinance is hereby declared to be an emergency measure necessary for the preservation of public peace, health and safety of the inhabitants of the City of Canfield, Ohio. Said emergency exists by reason of the urgent need of the Sheriff's Department.

Section 4: That this Ordinance and all deliberations relating to the passage of this Ordinance were held in open meetings of this Council, all pursuant to Section 121.22 of the Ohio Revised Code and Section 3.11 of the Ohio Revised Code.

PASSED IN COUNCIL THIS _____ DAY OF _____ A.D. 2024.

PRESIDENT OF COUNCIL

ATTEST:

CLERK OF COUNCIL

CERTIFICATION OF PUBLICATION

I, the undersigned Clerk of Council of the City of Canfield, Ohio, hereby certify that the foregoing Ordinance was posted in a prominent place at the Municipal Building, Canfield, Ohio for seven continuous days, to-wit: _____

CLERK OF COUNCIL

APPROVED AS TO FORM:

MUNICIPAL ATTORNEY

Introduced by: _____
First Reading: _____

RESOLUTION

A RESOLUTION AUTHORIZING THE CITY MANAGER TO APPLY FOR, ACCEPT, AND ENTER INTO A WATER POLLUTION CONTROL LOAN FUND (WPCLF) OR WATER SUPPLY REVOLVING LOAN ACCOUNT (WSRLA) AGREEMENT ON BEHALF OF THE CITY OF CANFIELD FOR PLANNING AND CONSTRUCTION OF WASTEWATER OR WATER FACILITIES; AND DESIGNATING A DEDICATED REPAYMENT SOURCE FOR THE LOAN

WHEREAS, the City of Canfield seeks to upgrade its existing water facilities; and

WHEREAS, the City of Canfield intends to apply for Water Pollution Control Loan Fund (WRCLF) or **Water Supply Revolving Loan Account (WSRLA)** for the planning and construction of the wastewater or water facilities; and

WHEREAS, the Ohio Water Pollution Control Loan Fund (WRCLF) or **Water Supply Revolving Loan Account (WSRLA)** requires the government authority to pass legislation for application of a loan and the executive of an agreement as well as designating a dedicated repayment source:

NOW, THEREFORE, BE IT RESOLVED BY THE COUNCIL OF THE CITY OF CANFIELD, OHIO:

Section 1: That the City Manager be and is hereby authorized to apply for a WPCLF or WSRLA loan, sign all documents for and enter into a Water Pollution Control Loan Fund (WPCLF) or **Water Supply Revolving Loan Account (WSRLA)** with the Ohio Environmental Protection Agency and the Ohio Water Development Authority for planning and construction of a wastewater or water facilities on behalf of the City of Canfield, Ohio.

Section 2: That the dedicated source of repayment will be water user fees.

Section 3: That this Resolution shall take effect and be in force from and after the earliest period allowed by law.

Section 4: That this Resolution and all deliberations relating to the passage of this Resolution were held in open meetings of this Council, all pursuant to Section 121.22 of the Ohio Revised Code and Section 3.11 of the Charter of the Municipality of Canfield.

PASSED IN COUNCIL THIS _____ DAY OF _____, 2024.

PRESIDENT OF COUNCIL

ATTEST:

CLERK OF COUNCIL

Certification of Publication

I, the undersigned Clerk of Council of the City of Canfield, Ohio, hereby certify that the foregoing Resolution was posted in a prominent place at the Municipal Building, Canfield, Ohio for seven continuous days, to wit: _____
_____.

CLERK OF COUNCIL

APPROVED AS TO FORM:

MUNICIPAL ATTORNEY

Introduced by: _____

Motion No. _____

**MOTION TO AUTHORIZE
THE CITY MANAGER TO APPLY FOR
F-1 AND F-2 PERMITS AS APPLICABLE FROM
THE OHIO DEPARTMENT OF COMMERCE/
DIVISION OF LIQUOR CONTROL FOR
FAMILY FUN NIGHT ON SEPTEMBER 19, 2024 AND
FALL FEST ON OCTOBER 5, 2024**

WHEREAS, the Council of the City of Canfield would like to conduct events on the Village Green from time to time where beer would be available for purchase; and

WHEREAS, Ohio law provides for the issuance of Temporary Permits for the sale of beer for such events, and

NOW THEREFORE, BE IT MOVED BY THE COUNCIL OF THE CITY OF CANFIELD;

Section 1. That the City Manager is hereby authorized to apply for an F-1 (Beer only) and F-2 (Beer & Spirituous liquor) as applicable Permits from the Ohio Department of Commerce/Division of Liquor Control for the Family Fun Night on September 19, 2024 and Fall Fest on October 5, 2024.

Section 2. That this Motion and all deliberations relating to the passage of this Motion were held in open meetings of this Council, all pursuant to Section 121.22 of the Ohio Revised Code and Section 3.11 of the Charter of the Municipality of Canfield.

PASSED IN COUNCIL THIS _____ Day of _____ A.D., 2024.

CLERK OF COUNCIL

Certification of Publication

I, the undersigned Clerk of Council of the City of Canfield, Ohio hereby certify that the foregoing Motion was posted in a prominent place at the Municipal Building, Canfield, Ohio for seven continuous days, to-wit: _____

_____.

CLERK OF COUNCIL

APPROVED AS TO FORM:

MUNICIPAL ATTORNEY

Introduced by: _____

Motion No. _____

MOTION

A MOTION CHANGING DATES OF THE COUNCIL MEETINGS FOR THE MONTHS OF JULY AND AUGUST, PURSUANT TO SECTION 3.09 OF THE CHARTER OF THE CITY OF CANFIELD

WHEREAS, Council is authorized to have one (1) meeting per month during July and August, pursuant to Section 3.09 of the Charter of the City of Canfield; and

WHEREAS, Council deems it desirable to operate under this curtailed schedule for these months.

NOW, THEREFORE, BE IT KNOWN BY THE COUNCIL OF THE CITY OF CANFIELD, OHIO:

Section 1. The meeting for July shall be held on July 17, 2024. The Caucus shall begin at 5:30 P.M. with the meeting to convene at the conclusion of the Caucus.

Section 2. The meeting for August shall be held on August 14, 2024 The Caucus shall begin at 5:30 P.M. with the meeting to convene at the conclusion of the Caucus.

Section 3: That this Motion and all deliberations relating to the passage of this Motion were held in open meetings of this Council all pursuant to Section 121.22 of the Ohio Revised Code and Section 3.11 of the Charter of the Municipality of Canfield.

PASSED IN COUNCIL THIS _____ DAY OF _____ A. D, 2024.

CLERK OF COUNCIL

Certification of Publication

I, the undersigned Clerk of Council of the City of Canfield, Ohio, hereby certify that the foregoing Motion was posted in a prominent place at the Municipal Building, Canfield, Ohio for seven continuous days, to-wit: _____

CLERK OF COUNCIL

APPROVED AS TO FORM:

MUNICIPAL ATTORNEY

Introduced by: _____

Motion No. _____

A MOTION AUTHORIZING THE SALE OF A 2019 CHEVROLET
TAHOE TO A POLITICAL SUBDIVISION OF THE STATE

WHEREAS, the City of Canfield has declared a 2019 Chevrolet Tahoe as surplus; and

WHEREAS, the City of Canfield wishes to sell the Vehicle to the Mahoning County Sheriff's Department; and

WHEREAS, Ohio Revised Code 505.10 states that if the property is conveyed to another political subdivision of the state, no public auction is necessary.

NOW, THEREFORE, BE IT MOVED BY THE COUNCIL OF THE CITY OF CANFIELD, OHIO:

Section 1: that a 2019 Chevy Tahoe Vin #1GNSKAKC3K150660 be sold to the Mahoning County Sheriff's Department for \$25,000.00.

Section 2: That this Motion and all deliberations relating to the passage of this Motion were held in open meetings of this Council, all pursuant to Section 121.22 of the Ohio Revised Code and Section 3.11 of the Charter of the Municipality of Canfield.

PASSED IN COUNCIL THIS _____ DAY OF _____ A.D., 2024.

CLERK OF COUNCIL

Certification of Publication

I, the undersigned, Clerk of Council of the City of Canfield, Ohio hereby certify that the foregoing Motion was posted in a prominent place at the Municipal Building, Canfield, Ohio for seven continuous days, to-wit: _____

_____.

CLERK OF COUNCIL

APPROVED AS TO FORM:

MUNICIPAL ATTORNEY

MINUTES
CANFIELD CITY COUNCIL
REGULAR MEETING
APRIL 17, 2024 -5:30 P.M.

The meeting was called to order by Mrs. Oliver, President of Council, followed by the Pledge of Allegiance. The Clerk called the roll to which a quorum responded as follows: Mr. Dragish, Mr. Graham, Mr. Neff, Mrs. Oliver and Mr. Tieche.

Staff present: Christine Stack-Clayton, Finance Director; Jodi Flinn, Zoning Inspector; and John Rapp, Public Works Superintendent.

Absent: Charles Colucci, Chief of Police.

Under **PRESENTATIONS & PROCLAMATIONS**, there were none.

Under **APPROVAL OF MINUTES**, the Minutes of the Regular Meeting on April 3, 2024 were approved as presented.

Under **READING OF COMMUNICATIONS**:

MR. TIECHE: I have none.

MR. NEFF: I had a resident, take me to task for what he considered not having all the facts on our position on the Fire merger. I said, "We're still open to listening to any new facts that come up." That was my answer. We made that decision because we felt that a very high percentage of our citizens were not interested. That's all I have.

MR. DRAGISH: I have nothing.

MR. GRAHAM: I have nothing.

MRS. OLIVER: The only thing that I had was the same thing, a resident questioning why we made our decision. We stand by our decision. At this point, it's not going to change, unless other facts or anything come forward. We haven't received any at this point.

Under **READING OF REPORTS** of Committees, Boards, Mayor's Report, City Manager, Finance Director, Chief of Police, Zoning Inspector and Public Works Superintendent.

MR. TIECHE: I do not have a report this evening our meeting will be next month.

MR. NEFF: Planning & Zoning meets tomorrow night, so I don't have a report.

MR. DRAGISH: I have the Mayor's Monthly Statement to Council. Monies received and who they were paid to and from, the net collections to the city was \$1,021.01.

MR. GRAHAM: I have no report this evening.

MRS. OLIVER: I'm on the Fire Board and our meeting is not until Monday. It's next Monday at 5:30pm, if anybody is interested in attending. Our Public Works Superintendent, Mr. Rapp.

PUBLIC WORKS SUPERINTENDENT: Good evening. Yarian is still working on Briarcliff and Bradford. They're into the restoration, taking advantage of the good weather. They were actually working as of 4:30 when I left that street. Our crews are out landscaping, mulching, you probably see them at the park and up here at the city building. We usually spend about a week to a week and a half on that, getting everything ready for spring. We've even started mowing. Limb and Stick, we were in zone 3 this week. We'll finish that up at the end of the week and we'll begin zone 4 on Monday. If you have any questions regarding rules and regulations or if your street is included in that zone, it's all on the city website. We will also be beginning lead & copper samples soon, I believe the 29th, right Patty?

CLERK: Right.

PUBLIC WORKS SUPERINTENDENT: We appreciate all the participants. A couple of years ago, they upped our lead and copper samples. They did it everybody, Niles, everybody that was fed from MVSD. We're at 40 samples every 6 months. We only had like 30 participants and now we just added like 30 more. We appreciate everybody's cooperation in getting the samples and leaving them on the doorstep for us. Also, we dropped the clock off to Mr. Oliver, he's going to start digging into that thing and it sounds like a hefty task but it seems like he's ready to do it.

MRS. OLIVER: He already started.

PUBLIC WORKS SUPERINTENDENT: That's all I have.

MRS. OLIVER: Thank you. Since you mentioned the city website, I would ask Mr. D'Apolito, if you could elaborate on that, since you've had some questions on social media reading the website. Thank you. Our Finance Director, Mrs. Clayton,

FINANCE DIRECTOR: Utility Online Bill Payment is currently unavailable. We've got in on our website and we put it out on social media today. Payments can be made at the municipal building during regular business hours or 24/7, there is a drop box in the lobby of the police department. We've starting moving all of the data from utility billing to the new software today. Tomorrow, we'll start proofing the bills that are produced out of the new software and we'll have to verify all of the customer information in the new software, once they populate all of that in. We're doing billings out of our current software and out of the new software and we're going to compare them. If anybody sees any errors in the next couple of months, please

contact us, as soon as possible, so that we can get it fixed. Hopefully, I'll have the online bill payment up, as soon as we get all of that verified, in the new software.

MRS. OLIVER: Thank you. Our Zoning Inspector, Mrs. Flinn.

ZONING INSPECTOR: Thank you, Mrs. Oliver. For the month of April, we issued 2 beekeeping permits, 4 garage sale permits, 7 zoning permits totaling \$215.00 for a valuation of \$34,746.00. Total permits issued for the year is 38, for a valuation of \$963,263. I have an update on a couple of projects, big one's that people have been asking about. We're waiting on a resubmittal of the site plans for the Hercules Car Wash. I did issue a permit for work to begin at the old IGA building, we're waiting on them to pick them up. The last thing, on Monday, I'll be going out to Millennial Moments for a sanitary inspection and this is on their second home of the year.

MR. DRAGISH: Do we know where the beekeeping permits were issued for?

ZONING INSPECTOR: I don't have the addresses but it was on Main and Broad, maybe.

MRS. OLIVER: Our City Clerk, Mrs. Bernat.

CLERK: Thank you. The Concerts on the Green schedule is finalized. It is available on our website. The concerts start June 10th and they run through August 19th, from 7:00pm to 8:30pm. This evening, the Civil Service Commission is administering the test for the Patrol Officer position; we had 7 applicants. That's all I have.

MRS. OLIVER: Thank you. Chief Colucci is not here. We'll go onto our City Manager, Mr. D'Apolito.

MR. D'APOLITO: Thank you, Mrs. Oliver. On behalf of the Chief, he's been off the last couple of days, on vacation. He wanted everyone to know that we will be meeting on Friday, the police department and some of the city hall staff, to set up the schedule for the city/police events, such as Movie Night, Safety Day, and Christmas in July. We're going to get that going again for this summer. We'll have those dates and times finalized.

I also want to take a minute to recognize Sam Oliver for his willingness to volunteer to get the clock restored. I know his work, he's incredibly talented. I'm looking forward to see how the clock turns out. I was also going to mention that it was delivered by Public Works to his shop on Tuesday.

Something that is important to a lot of people and we get many phone calls about Route 224 and Main Street, the patching job on the asphalt. We've been dealing with this for some time. We have had some very good negotiations with Lindy. I hope to have some resolution for council in the next week or so. I think we're going to get a really good result. I offered something that is a little different and I think they're receptive.

Finally, in regards to the city website. That is something that has caught my attention, since before I started here. It definitely needs a lot of updating. It definitely needs to have the links attached to it, as to where to go. The third-party vendor that we deal with here, I've been meeting with them multiple times, almost by-weekly. Our bill has been reduced greatly from where they started, when I first got here. I didn't think we were getting what we were paying for. They've been great about working with us. Ultimately, we'll decide whether it's going to be done in-house or a third-party vendor. Just to let everyone know, it's on my radar, it has been since I got here. Everything, everybody thinks about the website is correct. We're trying to make it a complete change. It will look very different in a short time.

MRS. OLIVER: Thank you. I will say, that clock is a lot larger in person. I thought the top of the clock was coming and it's all one piece. It's definitely large and heavy but I know he has good things planned to do to it, it's going to be beautiful.

MR. D'APOLITO: I was going to say something about him _____.

MRS. OLIVER: I like when you said it wasn't a wrist watch it's a clock.

MR. DRAGISH: I just want to say, a quick note, I noticed the carpet. That was one of the things I was going to say. I noticed it the other day at Mayor's Court on Monday. It smelled clean, it smelled good, it smelled fresh, and it looks fantastic. So, whoever, combination of things, it looks fantastic.

MR. D'APOLITO: I want you to know, I had absolutely nothing to do with this. (Laughter)

MRS. OLIVER: I thought those were new chairs for a minute because of the new carpet.

MR. D'APOLITO: They do match.

MRS. OLIVER: Last but certainly not least, our City Attorney, Mr. Fortunato.

ATTY. FORTUNATO: Really not report tonight.

MRS. OLIVER: Okay.

Under **PUBLIC QUESTIONS** on Reports:

MR. TIECHE: A question for Mr. Rapp. Do we take PFOS Samples?

PUBLIC WORKS SUPERINTENDENT: We do.

MR. TIECHE: Is that in conjunction with lead and copper? Is that a separate sample?

PUBLIC WORKS SUPERINTENDENT: It's a whole separate item. We have taken the samples but we do not have results yet.

MR. TIECHE: We get results back, then do our results go to MVSD?

PUBLIC WORKS SUPERINTENDENT: We keep an open relationship with MVSD. They will know what our results and we will know what their results are.

MR. TIECHE: Okay, thank you.

MR. D'APOLITO: It's all reported to the EPA.

PUBLIC WORKS SUPERINTENDENT: That is correct.

MR. TIECHE: I'm familiar with the process.

MR. D'APOLITO: Just for everyone else's clarification, that is who we actually report to.

MR. NEFF: Those samples are costly, to have them analyzed, right John?

PUBLIC WORKS SUPERINTENDENT: At this time, the U.S. EPA is funding the samples because they are getting together a baseline of the maximum contaminant levels for PFOS. We've been doing this for the past 3 years. Every so many months, they send us boxes, we send them back. We should be getting results back in the next couple of months. It takes a long time.

MR. TIECHE: The MVSD is in the process of designing a new filter for PFOS and that kind of thing, at the plant. They were part of a class action lawsuit as a settlement, I haven't heard exactly what the numbers are yet. I do attend their meetings on a monthly basis, so I sort of keep myself up to date on some of that.

PUBLIC WORKS SUPERINTENDENT: We just had a meeting with them last week and all communities received that water were at that meeting. They let us in on all that information. The engineering, they started the engineering process, they said by 2025, the summer of, the engineering is scheduled to be complete. They have a 2029 deadline for PFOS to meet.

MR. TIECHE: One of the interesting things that came about doing that study was part of the PFOS problems can be in the liquid that the fire service uses on chemical fires and that sort of thing, the Youngstown Municipal Airport changed their procedure so they're not adding as much PFOS to the water system.

MR. NEFF: John, one other thing, how are our residents doing with compliance on stick pick-up? Are we getting grass or any of the things that we've asked not to.....

PUBLIC WORKS SUPERINTENDENT: We're doing really good. No complaints. So, anybody that does have something, it was minor infractions, they will be notified by the door hanger. I think there has only been a couple.

MR. NEFF: Thank you.

MRS. OLIVER: Residents, any questions on the reports that you've heard? Hearing none.

Under Recognition of Persons Desiring to Appear Before Council:

MR. JOHN MORVAY: John Morvay, 7 Willow Way. First of all, I'll preface by once again thanking members of council for serving. I've been there. I've been on that seat and I know that sometimes it's a thankless job. I just wanted to thank you before I make my comments.

I'm going to start with the Cardinal Joint Fire District merger. We've heard the proverb or saying, if it's not broke, don't fix it. I don't think we should be that shallow in our planning. I sat on the Fire District Board for 15 years. I know the finances. I was enlightened by what they were trying to do with the additional revenue and economy to scale, combining those forces together. It made all the sense in the world. It seems like everyone's self-interest was put before the priority, of the whole. We lost sight of the benefit that would be acquired by everybody by the merger. Not to exclude anybody but the union, the city, the township, nobody gave it a chance. Again, I sat on this board for 15 years. It would have been a great benefit for both communities. It would have given us additional services and we probably would not have had to come back for another levy. These fire trucks are not 3 to 3 ½ million dollars, they will be 4 million dollars here shortly, ambulances are a couple million dollars to equip them with the right equipment and such. Just my comments, I think we were short sided on that. We should have studied it. Here is another saying or Proverb, We made our bed, now we have to lie in it. It's not going to go. I've talked to several parties and it's not going to happen with any information that comes out. I don't believe that council stood together in that decision. I don't think individuals would stand together with that decision, based with increases in the next couple of years.

Some residents are probably going to be upset with me, this is the pump track issue. I want to thank Lex Calder for expanding our resources at Fair Park, similar to what we did at Greasel Park with the Pickleball Courts. God forbid, people are there and it's vibrant. Kids are there and enjoying it. That's terrible. In the paper, there were 60 residents that are concerned about the noise, traffic and safety. My grandchildren live right there. They live right at Fair Park. I'm at that park almost every night with them. I've never had anybody disrespect or mistreat or any concern whatsoever about safety or hoodlums or whoever they think is going to embark on there. I'd encourage before any decisions are made that people go out there and yes, there are football teams out there, baseball teams out there, there are kids playing on the playground. That's what you want in a park. That's why we build parks. If we're not going to use them, let's just close them down. (Mr. Morvay was reading from the newspaper) An Akron Police Officer asked me why anyone would want to put one next to the playground. They're talking about the

pump track. Again, God forbid, the kids come and use it. It says here, kids on the playground, equipment, dogs walking. Yeah, it's a neighborhood park. Again, why do we have a park, let's encourage that. That's what it's for. In that same article, Lex Calder was called out that he's building a personal playground for himself and his children. I think that's wrong. I think that's a form of bullying. It's okay not to want the park there or the pump track there but don't make personal attacks on people that put their time, effort. Lex has donated time, talent and treasure in building this park and encouraging this pump track. All he has asked in the past was what else do we need? Do we want to put a bocce court in? He's throwing out ideas. Don't attack him personally. My final comment, if we're not going to encourage this kind of utilization and build where there is more usefulness to these parks, let's just close them down. Thank you.

MRS. OLIVER: As you know, Mr. Morvay, I have the utmost respect for you. You're like a mentor to me. You always have been. I agree with you on using the park. I'll have to respectfully disagree in regard to the fire merger. As you know, I sit on the board now, and with being on that board a very short time and sitting there with Mr. D'Apolito as well. It was made very clear to us that, that was going to happen whether we like it or not by a few individuals. Unfortunately, the only information they ever showed us was all the pro's of doing this. We all know that all things come with pro's and con's. Nothing can be 100% good. There is going to be something that's negative. But they didn't have anything negative. They made it clear that they were getting it done and it was going to happen very quickly. So, we made a unified decision to stop that from happening, until we had more information. Once it's done, it's done. Then the fallout would begin, where it would affect people with things that are unknown at this point. That is why we made our decision. So, they couldn't go and just put something in place without anybody else knowing. They kept us in the dark. They still have to this day. They have not given us information. This committee that they say they have consisted of two people. I don't know about you but I've never anywhere where a committee has only two members. So, that is why we made our decision. I can say, we stand by that. Those are the reasons.

MR. NEFF: I would like to comment, I'm surprised that John, you're saying that it's closed. I think we made the decision that, as of now, we're against it. We didn't say that we wouldn't be looking at additional information and facts, if they came out. I don't know how everyone else feels but I thought we just agreed to, at this point in time, with the information that we have, that we would be against a merger. I thought that that Fire Board is still researching. I would think that our council is open and forward thinking enough, we'd review new facts, if they came out or when they come out. That's just my comment. Thanks.

MRS. OLIVER: That's exactly what I feel we all believe up here. Any other comments? Anyone else wanting to speak, please state your name and address for the record.

LEX CALDER: Lex Calder, 145 Willow Bend Drive. I'm sorry I missed the meeting last time. I read about it. I saw it. It was probably better that I wasn't here, I guess. I was in the woods in a log cabin with my family and my friend. We were in Gatlinburg for a couple of days to gymnastics regional finals for my son, who got a medal. Congratulations to him. Two things I

want to address, I'm not the President of the Parks Board. That was in the paper. I'm the Secretary. I took over J.T. Whitehouse's position. Two, the personal piece was a little bit puzzling to me. You guys have all been here with me the whole time. I assure you, I did not join the Parks Board, I don't volunteer at the school and the PTA. It's not just for my children. I'm not trying to improve this for my own personal use. I'm trying to improve this whole area to help give new amenities. I believe that parks should be more diverse. They should attract a bigger slice of the population than the up to 4th grade. There is nothing to defend here. I don't know Norma. I've never met Norma. I'd love to sit down with her sometime and have her understand what I'm doing and where I'm coming from. I appreciate all your support throughout this time. This has been by the book. I started the idea, brought it to you guys, got money from the state. I got home from Fayetteville, Tennessee. We stopped by a park there, kids were playing, had some lunch. I have a 3-year-old that is 95% potty trained, so we have to stop a lot. My kids came running over and were so excited, they said, dad there is a bike track here, right next to the playground. This is not an odd thing. This is very normal throughout the country. I've shown locally, all the parks within a 60 miles radius. All I'm trying to do is bring that culture to give new things for us to do, to give the new generation of kids that have opportunities through biking. One time I was there, there was a professional biker that was there, he's a cyclist around here, sponsored by a local shop, on a BMX Bike. He said, it's the first time I've been on my bike in 16 years because there is nowhere to ride them. We used to build our own tracks with plywood, they break and you fall. He said, this is awesome to have this. This will get a whole new generation of kids that are into it. That's what I'm trying to do. I appreciate your support. I just wanted to put that out there for the record.

MRS. OLIVER: Thank you. Is there anyone else desiring to speak before council?

Under **OLD BUSINESS**, we have none.

Under **NEW BUSINESS**, we have none.

Under **COUNCIL COMMENTS**:

MR. DRAGISH: Without getting into any of the issues of both of these topics; which I could probably include the bee but I won't. Nothing against the media or newspapers or anything like that but I think a lot of this back and forth in the papers. I've been to all of these meetings, obviously and I hear all the information from both sides so, the decisions we make here, and we really haven't made any decisions, to be honest with you. The decisions made here are by the facts that come into us. If people want to read the papers and slam people, that's fine but we didn't say that to you. That's my feeling about this. We take the facts and we make our decisions on the facts. Nothing else, not hearsay, not questions that are not proven or complete. That's my comment.

MRS. OLIVER: Thank you. Mr. Graham.

MR. GRAHAM: Well said, Mr. Mayor. I believe we look at the facts before a decision is made and I appreciate everybody's input. I concur with what you previously said. A number of questions, if I live in the city or the township, how this was all going to be worked and to this point, I haven't received that information. Thank you.

MR. TIECHE: I have no additional comments.

MR. NEFF: I would like to thank you, Lex. I think it's really wonderful when residents step up and try to help our community. We really do have a beautiful park in Fair Park, it's 40 acres. Years ago, we did a study to put in a bike lane around Canfield and try to connect the schools and make a big circle. I hope we can continue with that and find funding and grants. It might eventually lead to a connector from the bike path. Good job. We are always open to hear people's concerns and try to react accordingly.

MRS. OLIVER: Thank you, Mr. Morvay and Mr. Calder for coming out this evening. Exactly what Mayor Dragish said, we make our decisions that we feel is in the best interest of our residents, based on the information that we have. Unfortunately, we have no information further, then what we already said. That is why we have our decision the way that it is at this time. Thank you, very much for coming out and expressing how you feel. I would like to adjourn this meeting. Do I have a motion to adjourn?

MR. DRAGISH: So, moved.

MR. GRAHAM: Second.

MRS. OLIVER: This meeting is adjourned.

PRESIDENT OF COUNCIL

ATTEST:

CLERK OF COUNCIL